

Y22	ABS modulator
G1	Alternator
C1	Battery
31	Battery -
30	Battery +
S6	Combination switch
S31	Fog lamp switch
F	Fuse
X28	Fuse box/relay plate
S1	Ignition switch
15	Ignition switch - ignition ON
S39	Inertia fuel shut-off (IFS) switch
A171	Relay module
K152	Secondary air injection (AIR) pump relay
M1	Starter motor

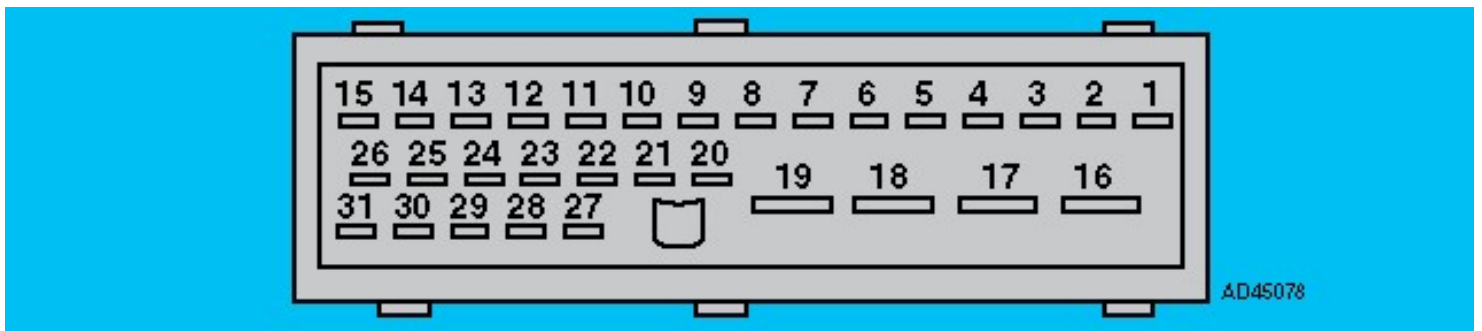

bl = blue	br = brown	el = cream	ge = yellow
gn = green	gr = grey	nf = neutral	og = orange
rs = pink	rt = red	sw = black	vi = violet
ws = white	hbl = light blue	hgn = light green	rbr = maroon
x = braided cable	y = high tension	z = non-cable connection	

NOTE: In certain diagrams (Citroen, Peugeot & Renault), colour codes are replaced by numbers which are used to identify a particular cable and not the colour. In this instance, the cables will be numbered at each end close to the harness connector.

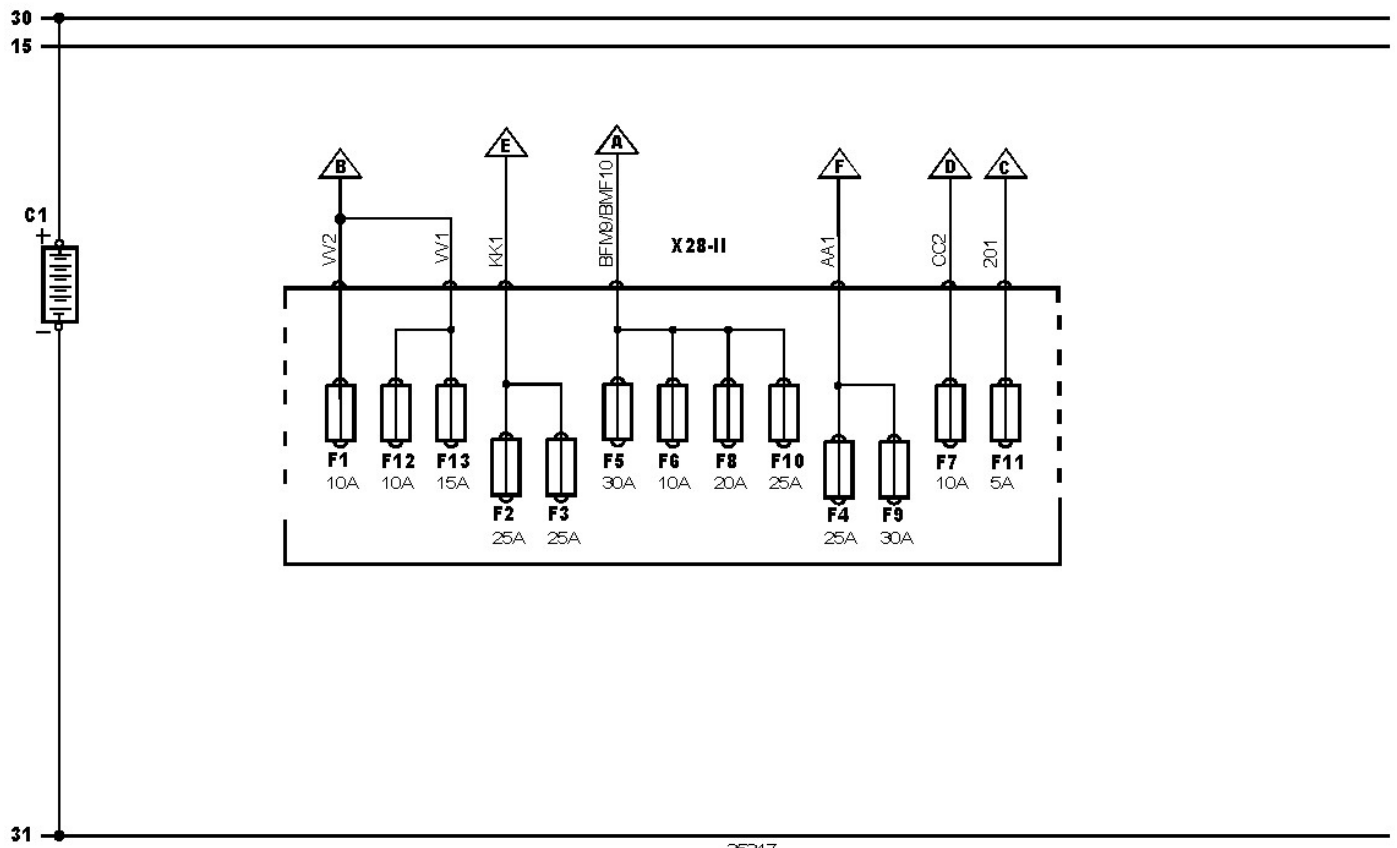
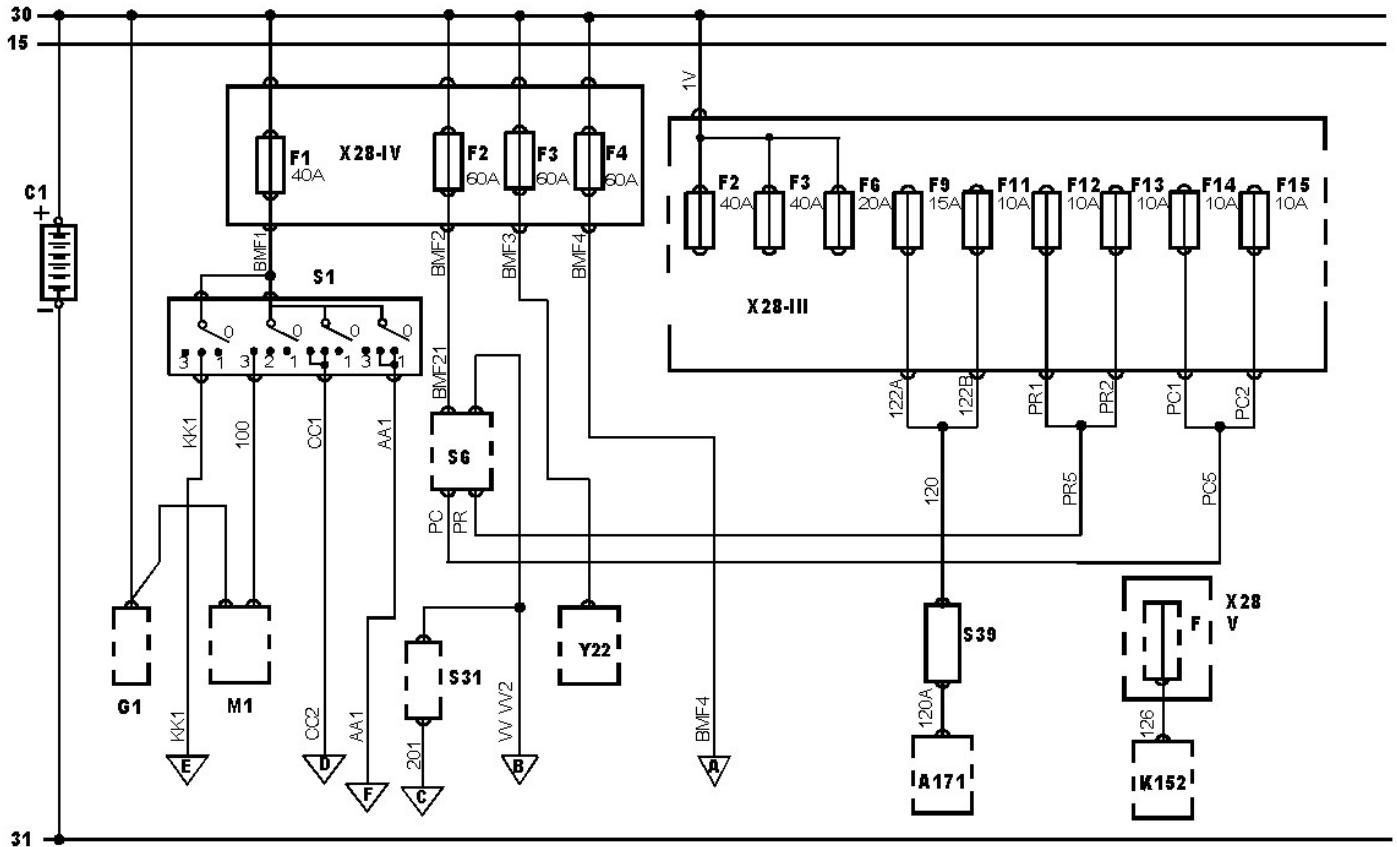

35317